

# WORLD OF PAPERSHIPS®

## Dutch design cardboardmodels

World of Paperships models can be ordered through [info@worldofpaperships.nl](mailto:info@worldofpaperships.nl)

Navigation cabin starboard side

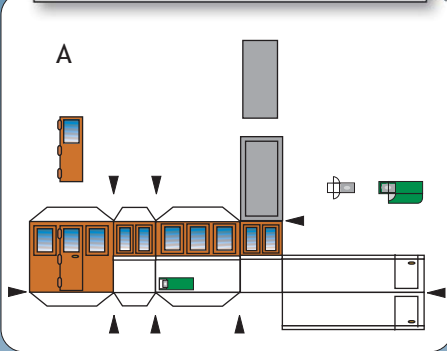

Navigation cabin port side

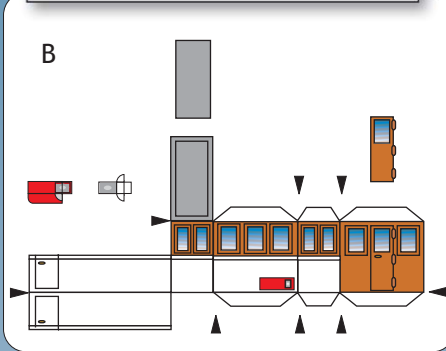

Steerhut roof details

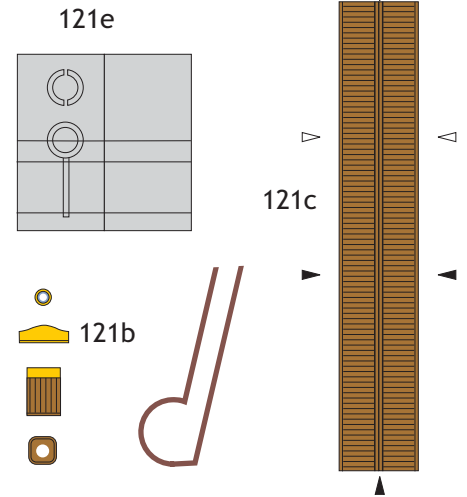

Steer hut roof deck + steering deck

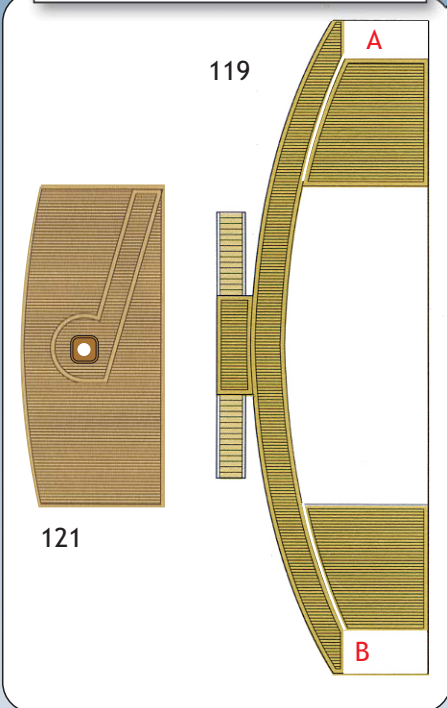

alternative covers

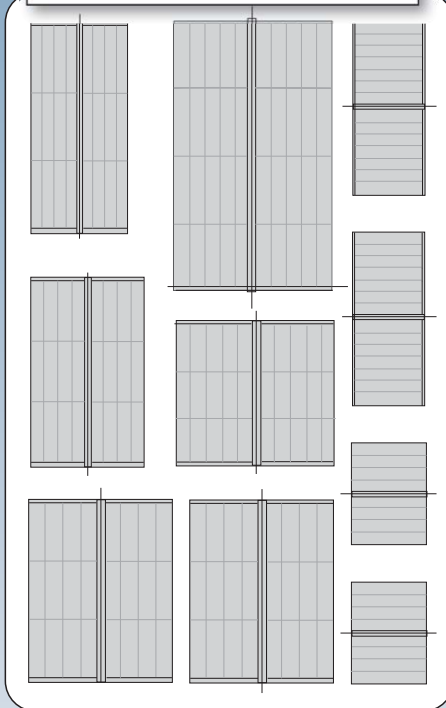

tent frame deck 85

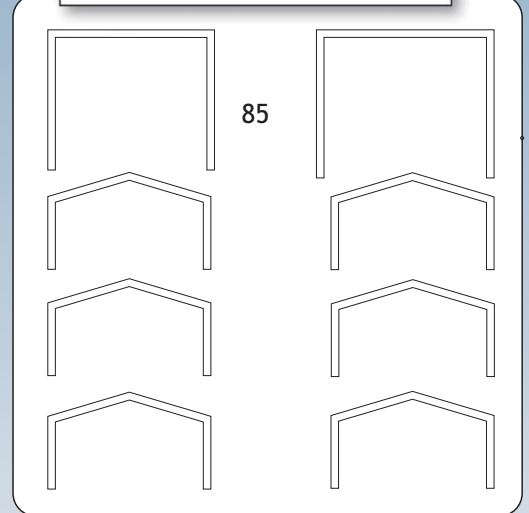

Wind screen supports, deck 147

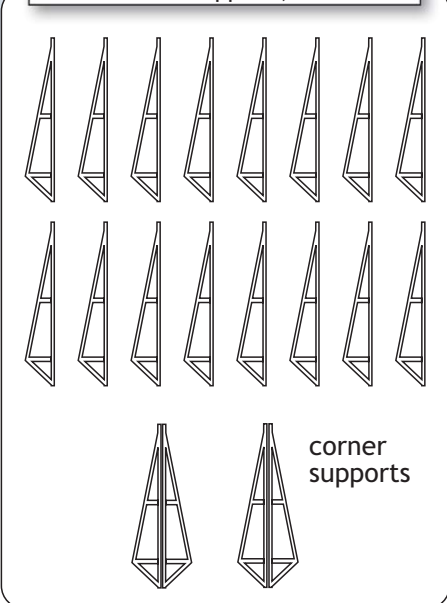

tentframes deck 89

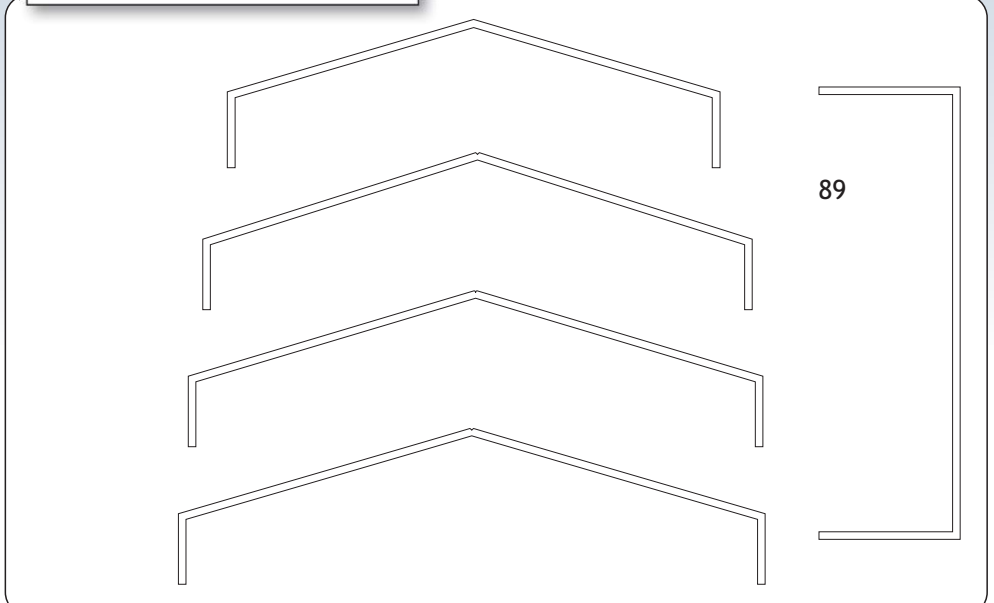

# WORLD OF PAPERSHIPS<sup>©</sup>

## Dutch design cardboardmodels

World of Paperships models can be ordered through [info@worldofpaperships.nl](mailto:info@worldofpaperships.nl)

TENTFRAMES DECK 106, 129

106

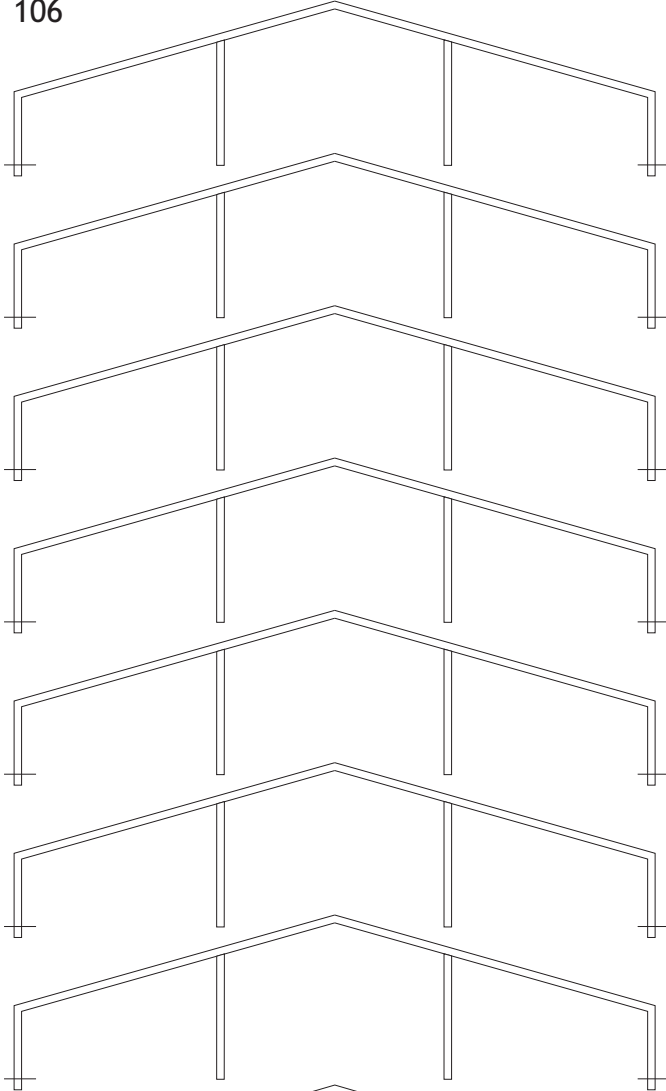

COVER  
SWIMMING  
POOL 129

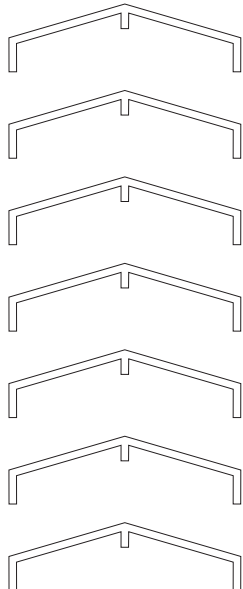

TENT FRAMES DECK 89, 25

89

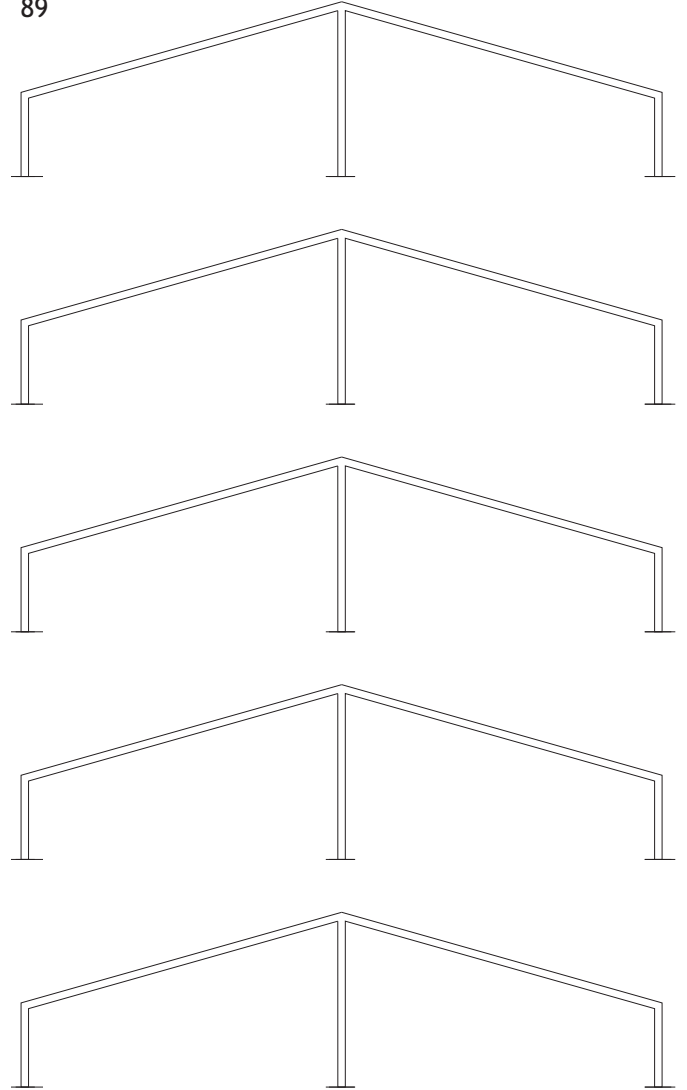

25

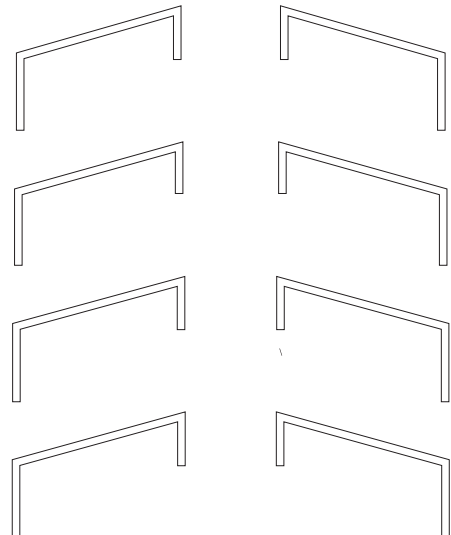

ADDITIONAL DETAILS FOR MS JOHAN VAN OLDENBARNEVELT (SCALE 1: 250) PUBLISHED BY SCALDIS CARDBOARD MODELCLUB, THE NETHERLANDS. This set is made available as a free download by World of Paperships; any commercial use in whatever form is not allowed.

# WORLD OF PAPERSHIPS<sup>©</sup>

## Dutch design cardboardmodels

World of Paperships models can be ordered through [info@worldofpaperships.nl](mailto:info@worldofpaperships.nl)

tentcover (print on 60 or 80 grams paper)

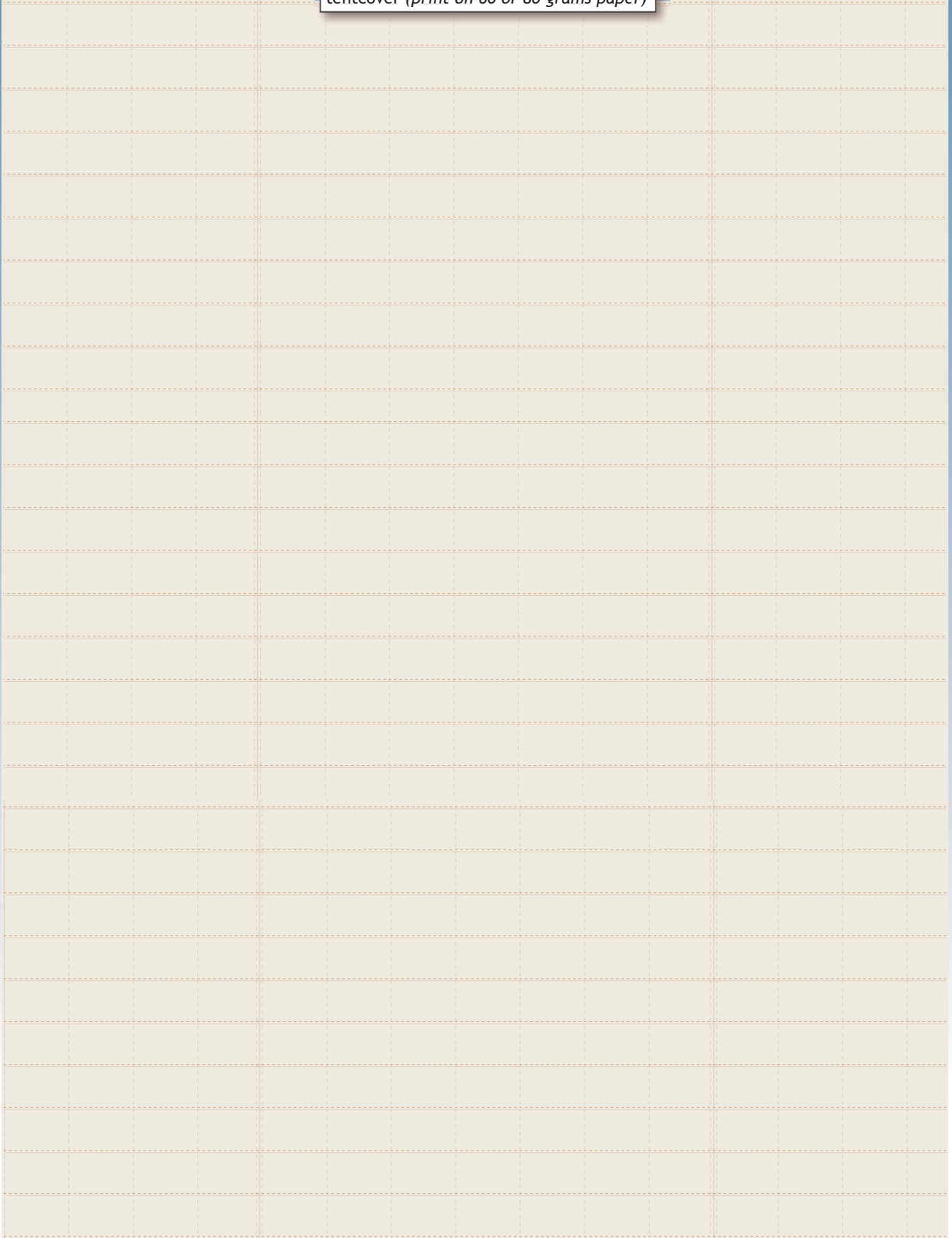

# WORLD OF PAPERSHIPS<sup>©</sup>

## Dutch design cardboardmodels

World of Paperships models can be ordered through [info.worldofpaperships.nl](http://info.worldofpaperships.nl)

### Building impressions and hints

#### Building impressions and tips

#### ms Johan van Oldenbarnevelt cq. ms Marnix van Sint Aldegonde

by Leen Lems and J. Giezenaar.

This model is a publication by Scldis Cardboard Modelclub. With the kit it is possible to build two versions of the ship (as ms JvO and ms MSA) in their pre-war II and after-war II appearance.

During testbuilding of the model, some minor errors were discovered. Therefore here some tips to adjust or to reduce the impacts of these errors.

#### **Errors in the construction plans:**

Nrs 61-62-63 should be Nrs. 41-42-43

Detail plan 3 should be 4.  
Detail plan 4 should be 3

In Fig 8 nr. 236 appears 2x, one part should be nr. 237, the second part 237 (the upper part of a david)

#### **Construction:**

There are no particular problems related to the construction of the hull, but please follow the instructions carefully.

- 39 and 40 (not mentioned) to be glued onto deck 27 (alinea 11, 12)
- 92/93 and 70/71 to be glued on 69
- Do not glue deck cabin 83 and part of 84 onto deck 49 yet. The white area of 83 located on deck 49 is too far to the front. This becomes obvious when trying to glue 84/85 onto the deckcabin. The backside of this deck will not fit to deck 27. The best solution is to shorten dek cabin 83 with about 4-5 mm and to colour the remaining white part 49 into the tan deck colour using e.g. a colourpencil or similar coloured feltpen.
- Tip: all decks are to be doubled for extra strength.
- 115 is approx 5 mm. too long where it meets 113.
- Glue 108 onto deck 106 against board 94. Glue 110/111 along deck border 106/107 (can also be excuted at a later stage), glue 112/115 deck 106/107 and enforce this by frames 116. Glue sairs 109 to extensions of part 108.
- Shorten 115 (where it fits 113) with approx 5 mm.
- Glue deckcabin 118 to deck 119 and board 120 onto deck 106, glue bridge deck 121 onto deck 119.
- Air ventilators 170 – 180: their location is marked by the symbols on the decks. There are too many 175 and 177 ventilators, 171 are too few. Tip (JvdW) scan all ventilators and print them on 80 grams paper, this will facilitate their construction).
- Only 50% of the davids are printed. Scan the available ones and print them on 200 grams paper or send an email to [info@worldofpaperships.nl](mailto:info@worldofpaperships.nl) for a additional set.
- Railings: Scldis Cardboard Model Club has detailed JvO laser cut sets available for smaller parts, including railings. You can also order (standard) railingsets through [Pleiner Laser cut sets](http://www.pleiner.com)

ADDITIONAL DETAILS FOR MS JOHAN VAN OLDENBARNEVELT (SCALE 1: 250) PUBLISHED BY SCALDIS CARDBOARD  
This set is made available as a free download by World of Paperships; any comments are appreciated.

This additional detail set is based upon contemporary photographs of the actual ship only, and therefore cannot be guaranteed to be 100% historically accurate. This set can be combined with the laser detailsets as supplied by Scaldis Cardboard Modelclub. The laser sets do include the tentframes. This download set is dedicated to the founder and owner of Scaldis: Wim van der Meer as a token of appreciation for his efforts to promote cardmodelling in the Netherlands.

# WORLD OF PAPER Dutch design cardboard

World of Paperships models can be ordered through [www.worldofpaperships.nl](http://www.worldofpaperships.nl)

photo's of the Scaldis model, build by Jeroen van den Worm, cardboard modeller and designer

